

ROOF PLAN

- © This drawing is copyright.
- 1 Do not scale this drawing.
- 2 Errors and omissions to be immediately notified to Architect.
- 3 All dimensions to be checked on site.
- 4 To be read with relevant Engineers drawings.

Note:
Furniture and fittings shown are indicative.

Wardrobes in bedrooms are not counted as part of designated storage areas.

Notes:
All dimensions in millimetres

Refer to RMDA landscape drawings for landscape design

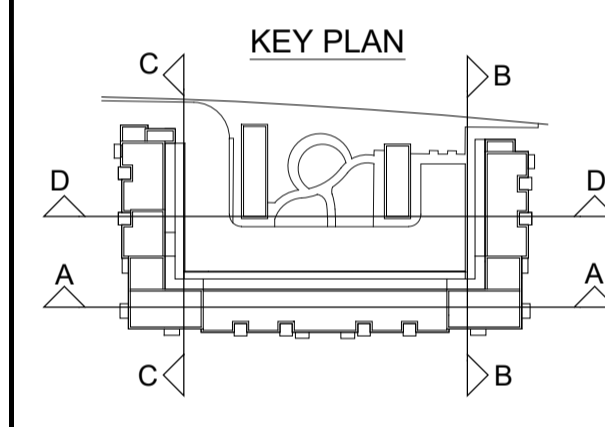
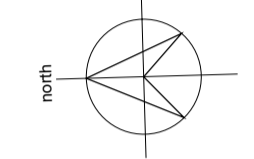

revisions description date ins

drawing no.	1640 P 114
scale	1:200 @A1
date	JUL '19
drawn	CQ
checked	RB
job	Block 11, Clongriffin, Dublin 13
client	Gerard Gannon Properties
issue	Clongriffin SHD 1 Planning

client
Gerard Gannon Properties

issue
Clongriffin SHD 1 Planning

CONROY CROWE KELLY
ARCHITECTS & URBAN DESIGNERS

65 MERRION SQUARE
DUBLIN 2
phone 01 6613990 fax 01 6765715
email info@cck.ie